

Type:	VLC__ (__=50,100,250,500,1000,1500) (e.g. VLC100)
eDMX	≤ __*512 (DMX via eDMX Nodes)
Total	≤ __*512 (e.g. 51,200 channels)
Type:	LPC X(X=10,20,30...100) (e.g. LPC 100)
eDMX	≤ X*512 (e.g. 51,200 channels) (DMX via eDMX Nodes)
Total	≤ X*512 (e.g. 51,200 channels)

Note: The VLC and LPC can be programmed and triggered in the same project. VLC channels are used to control a single composition of fixtures. The DVI-D input is local to the controllers channels.

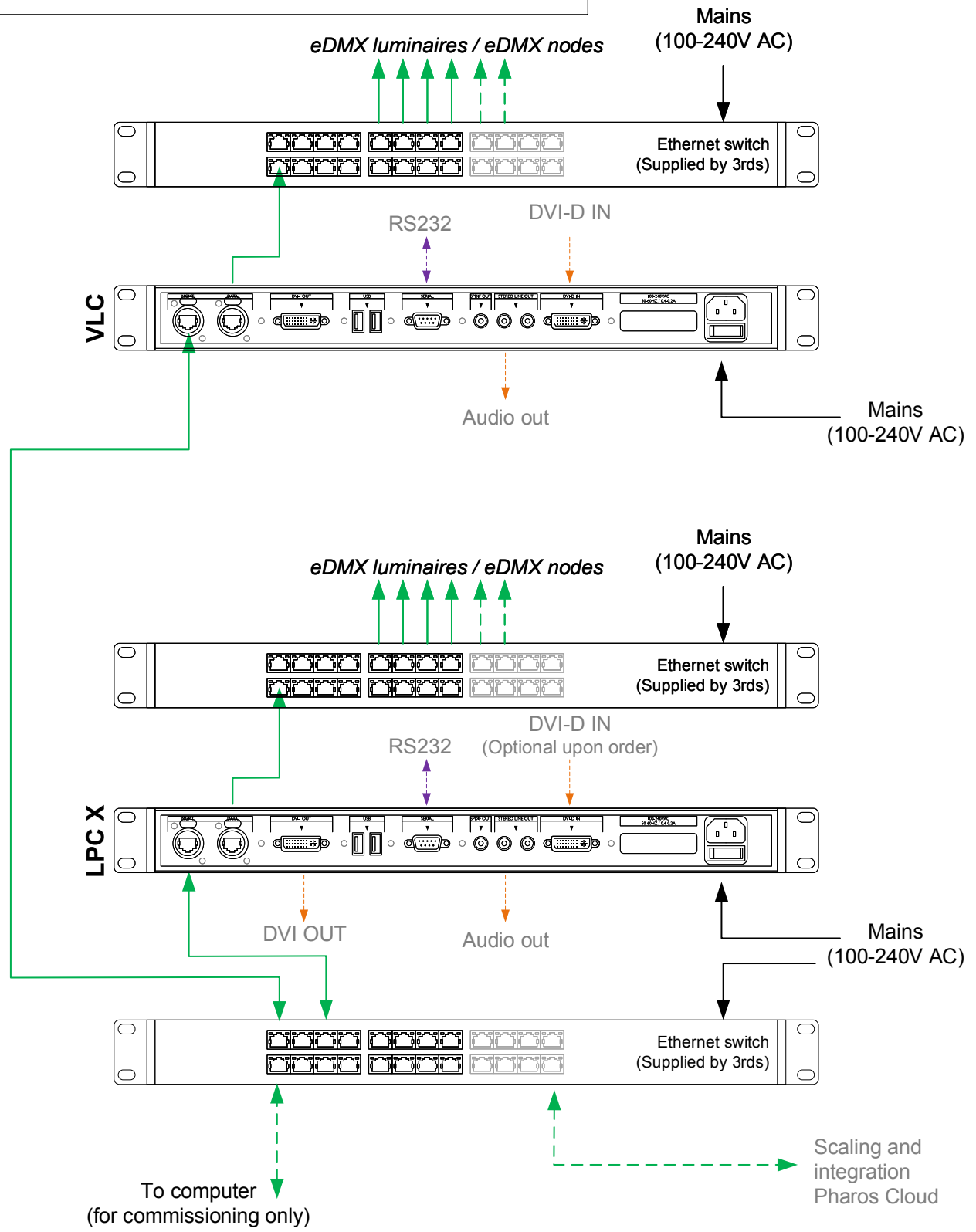

- Consult the **Installation Guide** for technical details
- See **General Notes.pdf** for information on cabling types
- **More configurations** are possible to fulfil any project
- Contact your supplier or visit our website for support



pharoscontrols.com

Reference:	2212		
Name:	LPC X & VLC (indiv. networks)		
Size:	Date:	Rev:	Notes:
A4	17/09/2018	V 1.0	Setup
	21/01/2019	V 1.2	Setup
Page:	27/05/2021	V 1.3	Minor adjustments