

Type:	VLC+ ___ (___=50,100,250,500,1000,1500,3000) (e.g. VLC+100)
eDMX	≤ ___*512 (DMX via eDMX Nodes)
Total	≤ ___*512 (e.g. 51,200 channels)
Type:	LPC X (X=10,20,30...100) (e.g. LPC 100)
eDMX	≤ X*512 (e.g. 51,200 channels) (DMX via eDMX Nodes)
Total	≤ X*512 (e.g. 51,200 channels)

Note: The VLC+ and LPC can be programmed and triggered in the same project. VLC+ channels are used to control a single composition of fixtures. The DVI-D input is local to the controllers channels.

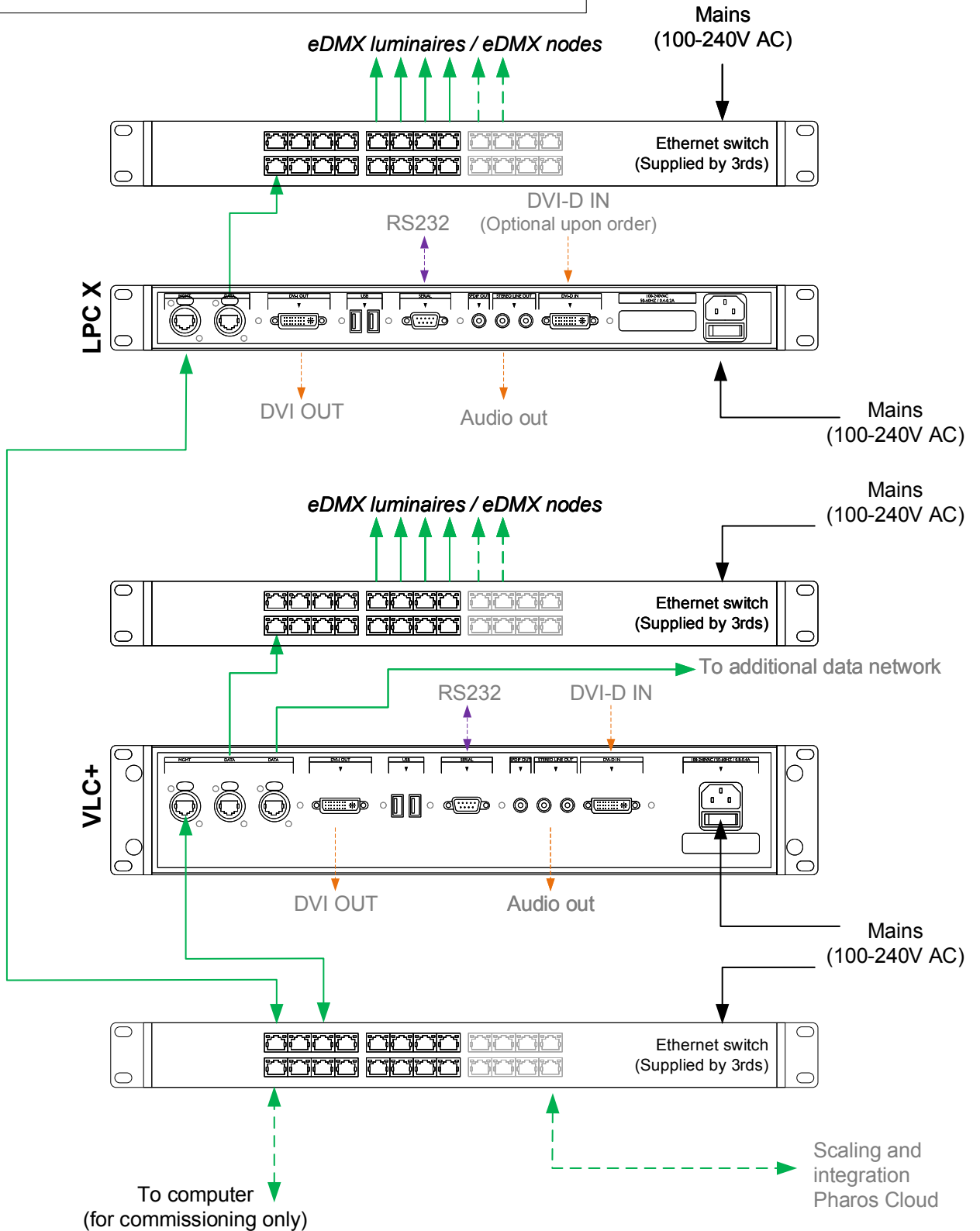

- Consult the **Installation Guide** for technical details
- See **General Notes.pdf** for information on cabling types
- **More configurations** are possible to fulfil any project
- Contact your supplier or visit our website for support



pharoscontrols.com

Reference:	2215		
Name:	VLC+ & LPC X (indiv. networks)		
Size:	A4	Date:	Rev:
Page:		17/09/2018	V 1.0
		21/01/2019	V 1.2
		27/05/2021	V 1.3
			Notes:
			Setup
			Setup
			Minor adjustments