

Type:	VLC__ ( __=50,100,250,500,1000,1500)(e.g. VLC100)
eDMX	≤ __*512 (DMX via eDMX Nodes)
Total	≤ __*512 (e.g. 51,200 channels)
Type:	VLC+__ ( __=50,100,250,500,1000,1500,3000)(e.g. VLC+100)
eDMX	≤ __*512 (DMX via eDMX Nodes)
Total	≤ __*512 (e.g. 51,200 channels)

**Note:** The VLC+/VLC can be programmed and triggered in the same project. Each set of VLC/ VLC+ channels are used to control a single composition of fixtures. The DVI-D input is local to the controllers channels.

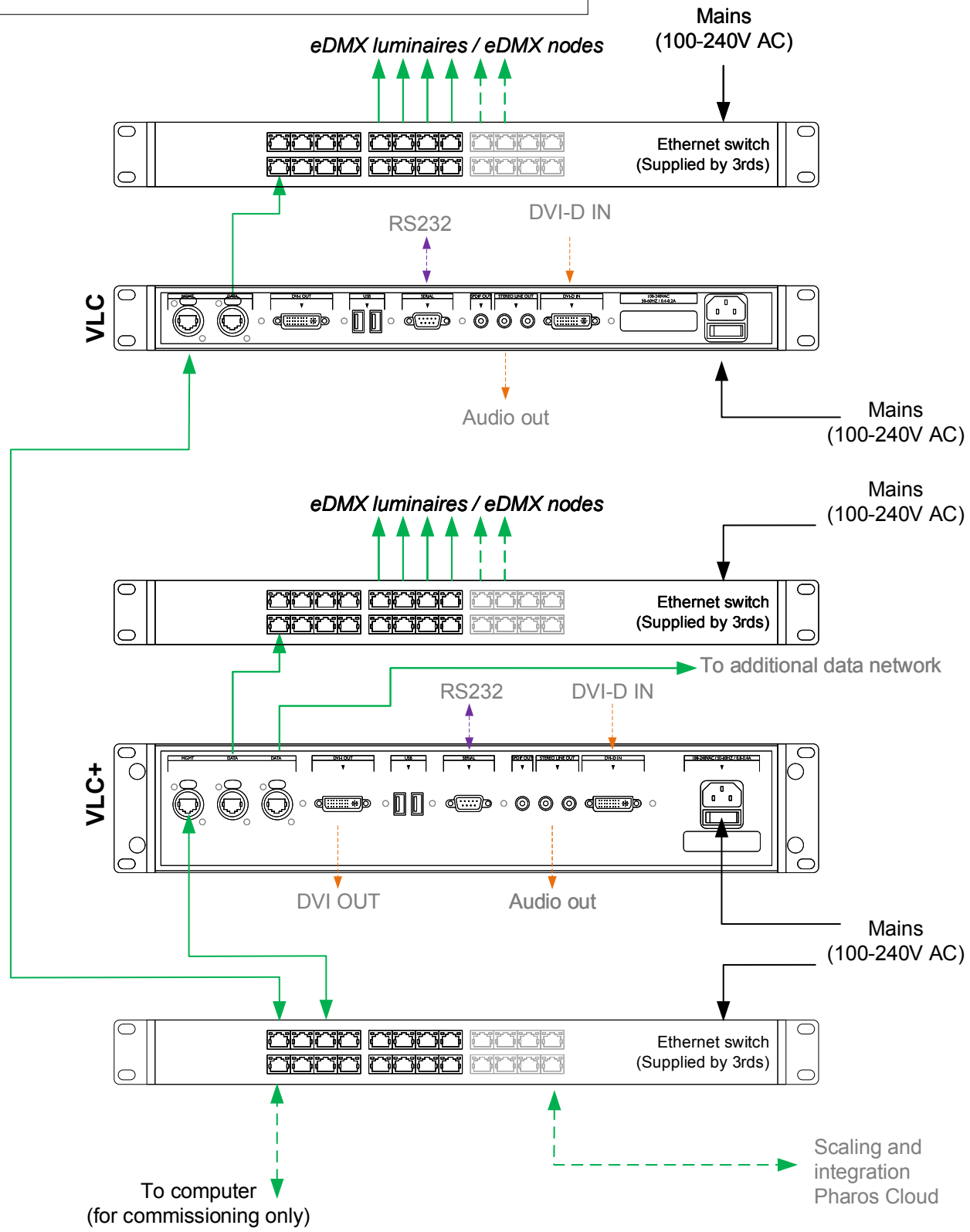

- Consult the **Installation Guide** for technical details
- See **General Notes.pdf** for information on cabling types
- **More configurations** are possible to fulfil any project
- Contact your supplier or visit our website for support



pharoscontrols.com

Reference:	2218		
Name:	VLC+ & VLC (indiv. networks)		
Size:	A4	Date:	Rev:
Page:		17/09/2018	V 1.0
		21/01/2019	V 1.2
		27/05/2021	V 1.3
		Notes:	
		Setup	
		Setup	
		Minor adjustments	