

DESIGNER VLC

VLC S2 INSTALLATION

The Video Lighting Controller (VLC) is designed to be rack mounted in a central control room for fixed installations. The 1U enclosure and 19" rack mounting complies with IEC 60297.

The unit is largely solid state and has been qualified to operate in a dry environment:

- Temperature range 0°C to 50°C (32°F to 122°F)
- Humidity 10-90% relative, non-condensing
- Ingress IP40

NOTE: Particular attention must be paid to cooling; under no circumstances should the airflow to the heat sinks be restricted and a rack fan cooling unit should be considered when multiple units are stacked together to maintain the correct ambient temperature.

NOTE: This equipment is not suitable for use in locations where children are likely to be present.

Since the unit requires no user intervention once installed it is suitable for remote installation with all configuration and management taking place over an Ethernet network. However, it is recommended that access can be gained in the unlikely event of a hardware failure.

The VLC is fitted with fan filters mounted on the front panel of the product. Should the filters become clogged, they need to be replaced. Please contact Pharos Support for further information.

VLC LAYOUT

The following drawings illustrate the layout of the VLC, refer to the following sections for details:

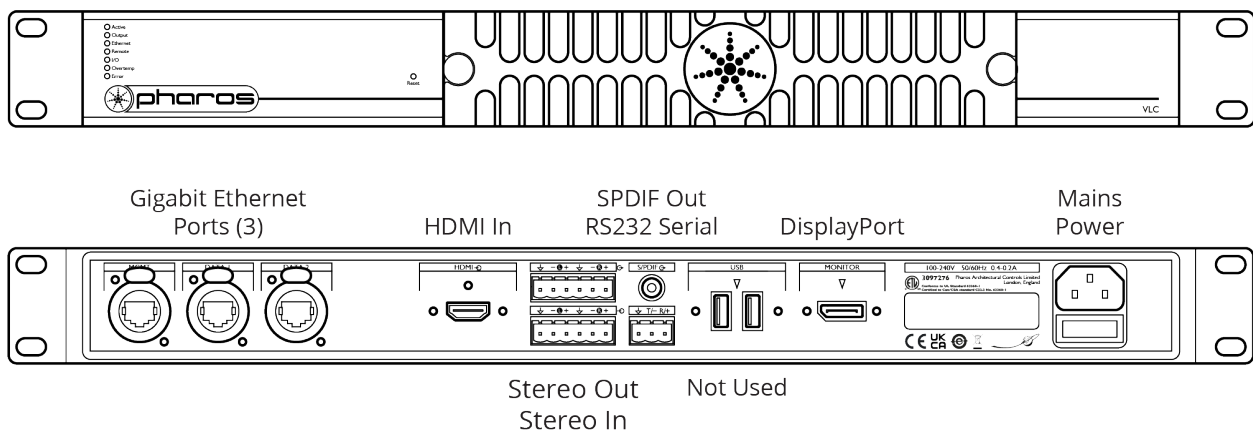

VLC VERSIONS

There are multiple versions of the VLC that differ only in the maximum number of control channels that can be accommodated. For example, the VLC 50 can control 50 DMX universes (25,600 channels) while the VLC 1500 can control 1500 DMX universes (768,000 channels).

The VLC can be used as a stand-alone controller or co-operatively with other Pharos Designer Controllers and Remote Devices, via an Ethernet network, to form a scalable system.

POWER SUPPLY

The VLC is mains powered via a fused, universal input power supply unit (PSU) compatible with all worldwide mains supply standards; 100-250V 50/60Hz.

The VLC will consume 40W typical (50W maximum).

NOTE: Power must not be disconnected when uploading project data nor during bootloader/firmware updates to the VLC as corruption of the data or software may occur, perhaps even rendering the unit inoperable.

CAUTION: For pluggable equipment, the socket outlet shall be installed near the equipment and shall be easily accessible.

ATTENTION: En cas d'équipement enfichable, la prise doit être montée près de l'équipement et doit offrir un accès facile.

GROUNDING

The VLC must be correctly grounded to electrical safety earth at all times.

REALTIME CLOCK BATTERIES

The VLC's internal realtime clock is battery-backed to ensure operation when the unit is not powered. The batteries should last for at least 10 years and are easily replaced when necessary, replacement battery: Renata CR2032 Lithium Button Cell.

CAUTION: Risk of explosion if battery replaced by incorrect type. Dispose of used batteries according to the manufacturer's instructions.

ATTENTION: Il y a un danger d'explosion s'il y a un remplacement incorrect de batterie. Mettre au rebut les batteries usages conformément aux instructions du fabricant.

MEMORY STORAGE

The VLC is shipped with a 128GB SSD which should be sufficient for most projects since the VLC's data storage is extremely efficient, even with a multitude of imported media files. However, a larger capacity drive could be fitted if required.

STATUS LEDS

The Pharos logo will illuminate when power is applied to the VLC. The red LEDs above indicate the unit's current status.

Active:	The Active LED flashes throughout the boot up procedure and lights solidly once this has been completed and is indicative of a fully functional unit.
Output:	The Output LED indicates that a valid project file has been loaded from storage and that playback & data output (eDMX) has started.
Ethernet:	The Ethernet LED indicates Pharos-related network activity (not network link) while the rear panel LEDs indicate communication on the various Ethernet ports of the VLC.
Remote:	Flashes when the unit has internet access, and will illuminate when the unit is connected to a Remote Site on Pharos Cloud or a Pharos Cloud Portal.
I/O:	Flashes with any activity on VLC's serial and audio ports. (Rear panel LED indicates HDMI input signal). When receiving data on the serial port the LED will blink briefly, when timecode is received, the LED will blink on initial acquisition and then again every 3 seconds of elapsed timecode, and when audio is being output, the LED will blink when the audio starts playing.
Overtemp :	The Overtemp and Error LEDs will illuminate if the processor core(s) reaches 95°C (203°F) indicating a fault in the system's cooling, typically caused by raised ambient temperatures. Consult the web interface's home page to monitor the system temperatures and take remedial action.
Error:	Illuminates when an error is detected. Remaining LEDs will then turn on to indicate error type (See Error Codes below).

ERROR CODES

Additionally, the Error LED in combination with other status LEDs is used to indicate any boot failures that prevent the unit from going active. In the event of a boot error, the Active LED will remain off, and the Error LED will illuminate with the following additional LEDs indicating the specific issue:

Output:	SSD Missing or Failed. Indicates the unit cannot detect or communicate with the SSD.
Ethernet:	SSD Corrupt. Indicates the unit can detect the SSD, but it does not contain a valid boot image.
Output + Ethernet:	Unable to communicate with front panel. Contact Support.
Remote:	Invalid hardware configuration. Contact Support.

Main board errors can usually be resolved by running the VLC Recovery Tool on a PC. This may format the SSD and reinstall the firmware. In such a case all project data will be erased and so an upload will be required to restore programming.

RESET SWITCH

The VLC may be reset by inserting a small blunt object into the reset hole on the front panel to depress the reset switch. The switch should be held for at least one second.

NOTE: The reset must not be operated when uploading project data nor during bootloader/firmware updates to the VLC as corruption of the data or software may occur, perhaps even rendering the unit inoperable.

WATCHDOG

The internal "watchdog" is enabled by default to reset automatically the VLC in case of a software crash as a result of either a coding error ("bug") or a random electromagnetic event such as a power brown-out or spike, nearby lightning strike or static discharge. Please refer to the Designer Help to learn how to disable this feature (not recommended).

PORTS

- Ethernet 1 - MGMT

A standard 10/100/1000BASE-T Ethernet connection may be made to this port for management and networking to other Pharos Controllers and Remote Devices.

- Ethernet 2 - DATA 1

A standard 10/100/1000BASE-T Ethernet connection may be made to this port to output data to lighting fixtures using Ethernet protocols (eDMX) such as sACN, Art-Net and KiNET.

- Ethernet 3 - DATA 2

A standard 10/100/1000BASE-T Ethernet connection may be made to this port to output data to lighting fixtures using Ethernet protocols (eDMX) such as sACN, Art-Net and KiNET.

- RS232 Serial Port

The serial port's data rate and format settings (baud, parity, stop bits, etc.) are configured using Designer. The port operates in full duplex with the following pinout:

↓	Signal ground
T/-	Transmit
R/+	Receive

The serial port is not isolated from the VLC's power supply. If isolation is required, it must either be provided by the connected device or a separate isolator should be used.

- USB

This port is not supported at the time of writing (refer to the current Designer Help).

- Audio Input - Stereo analog 

Balanced stereo audio input is provided @ 0dBV line level on a 6 way connector:

- ↓ Signal ground
- (L) Balanced audio left channel - (tie to ground for unbalanced)
- (L) + Balanced audio left channel +
- ↓ Signal ground
- (R) Balanced audio right channel - (tie to ground for unbalanced)
- (R) + Balanced audio right channel +

The audio input can accept linear time code (LTC) such as SMPTE/EBU on both channels, configured using Designer.

- Audio Output - Stereo analog 

Balanced stereo audio output is provided @ 0dBV line level on a 6 way connector:

- ↓ Signal ground
- (L) Balanced audio left channel -
- (L) + Balanced audio left channel +
- ↓ Signal ground
- (R) Balanced audio right channel -
- (R) + Balanced audio right channel +

- Audio Output - SPDIF

A standard RCA coaxial cable may be connected for digital audio output from the Controller. 2-channel PCM audio is supported.

- Video Output

DisplayPort for monitoring or video-mapped fixtures.

- HDMI Input

A standard HDMI connection may be made to this port to route video data to a Live Video Preset within the project.

HDMI cable retention:

Included with the VLC is a cable lock package including a cable tie base, cable tie and spare screw.

Installation:

1. Place the cable tie base around the HDMI cable as close to the connector as possible, with the cable tie grip facing away from the connector.
2. Secure the cable tie to the VLC using the locking screw above the HDMI port.
3. Connect the HDMI cable to the port.
4. Insert the cable tie into the cable tie base, firmly pulling on it to remove any slack.
5. To remove the cable, release the latch on the base.

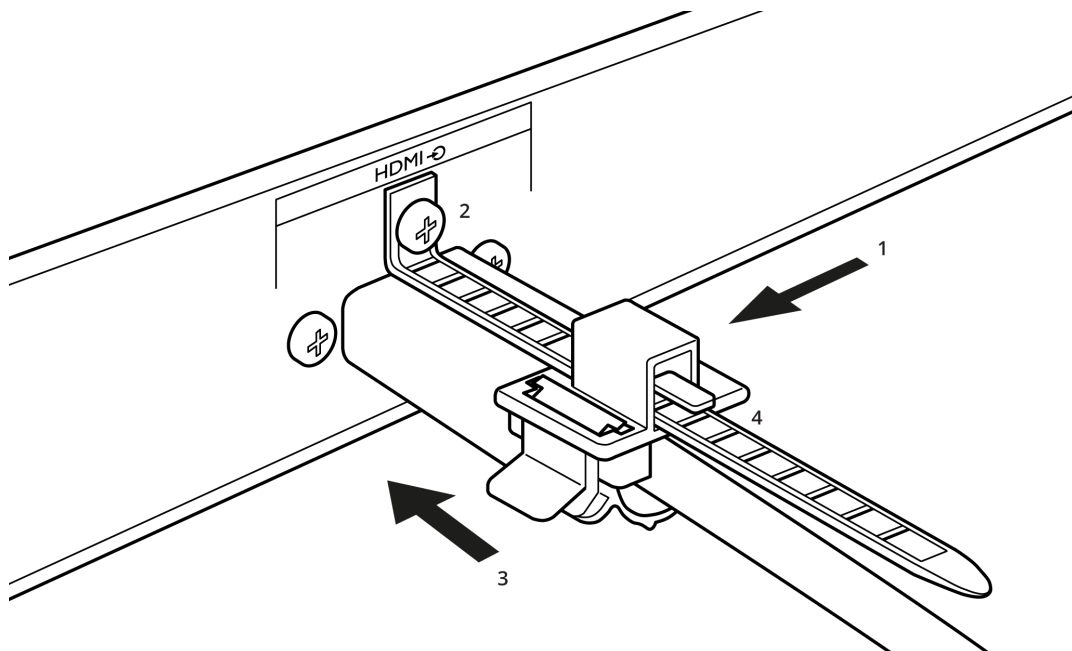

NOTE: Ports and third party equipment can be damaged when plugging or unplugging an energised system (hot-plugging). It is therefore advisable to remove power before making or breaking port connections.