

## EXPERT TOUCH 5

### EXPERT TOUCH 5 INSTALLATION

The Expert Touch 5 has been qualified to operate in a dry environment:

- Temperature range 0°C to 50°C (32°F to 122°F)
- Humidity 10-90% relative, non-condensing
- Ingress IP40

The unit is an ancillary device that provides a user interface to an Expert system. As such, it can not be used on its own but must have an Expert Control present on an Ethernet network to function.

The unit is designed to be permanently installed for convenient access. The Universal Mounting Plate (UMP, supplied) can be surface mounted directly to a wall with at least a 49mm hole for turret and Ethernet cable, or into UK, EU & US 1-Gang and UK 2-Gang third party backboxes commonly available on the market. The unit is securely fastened to the UMP with a tool-free bayonet-twist.

The following diagram illustrates a typical installation:

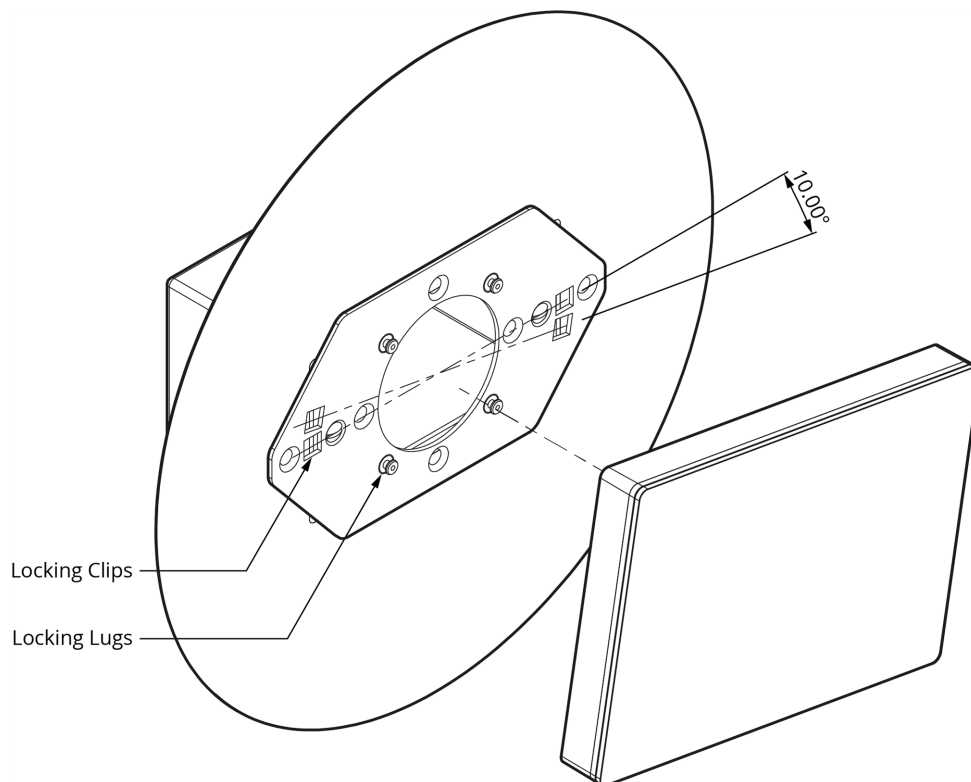

### EXPERT TOUCH 5 MOUNTING

To mount:

- Fit mounting plate to surface (back box optional, 49mm hole mandatory)
- Fit mounting plate in desired orientation (back box allowing)
- Plug in Ethernet cable into the RJ45 port

- Fit touch panel at 10 degrees clockwise angle onto locating lugs
- Rotate panel 10 degrees counter-clockwise to lock
- Locked position allows for +/- 1 degree adjustment

To remove:

- Pull short sides forward and rotate 10 degrees clockwise
- Remove from locating lugs
- Unplug Ethernet cable from the RJ45 port

### EXPERT TOUCH 5 LAYOUT

The following drawing illustrates the layout of an Expert Touch 5, refer to the following sections for details:

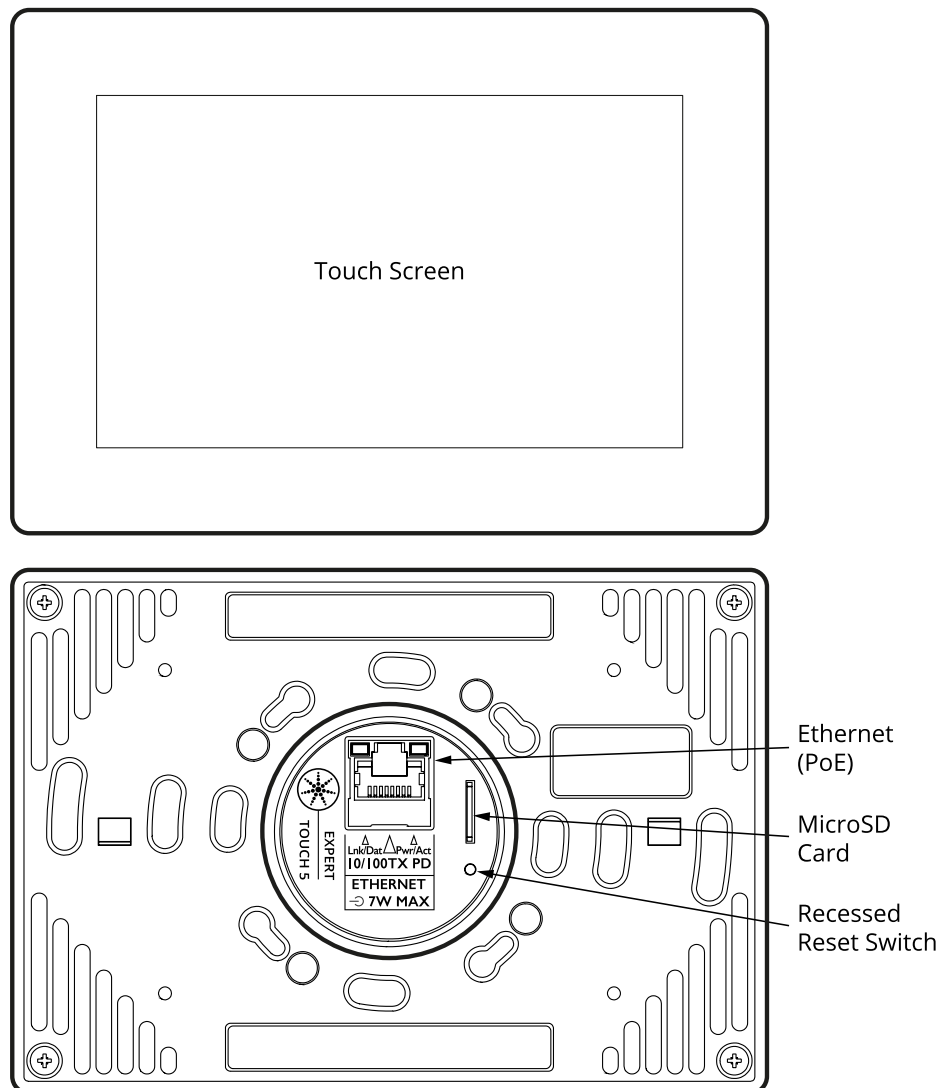

## POWER SUPPLY

The Expert Touch 5's are shipped without external power supply.

- Power-over-Ethernet (PoE)

A standard (802.3af) Power-over-Ethernet switch should be used to provide both power and a network connection to the Expert Touch 5 using a single cable.

Alternatively, if a PoE switch is not available, a compliant PoE midspan injector could be used.

The Expert Touch 5 operates as a PoE Class 0 device (0.44 - 12.95W) and will typically consume 7W.

## MEMORY CARD

The Expert Touch 5 is shipped with a 32GB MicroSD Memory Card.

## RESET SWITCH

The Expert Touch 5 may be reset by removing the device from the mounting plate and pressing the recessed reset switch, found below the MicroSD card slot.

**NOTE:** The reset must not be operated during firmware updates to the Expert Touch 5 as corruption of the software may occur, perhaps even rendering the unit inoperable.

## WATCHDOG

An internal "watchdog" will automatically reset the Expert Touch 5 in case of a software crash as a result of either a coding error ("bug") or a random electromagnetic event such as a power brown-out or spike, nearby lightning strike or static discharge.

**EXPERT TOUCH 5 BACK BOXES**

Back boxes are optional and independent of the universal mounting plate (UMP). The options are:

- UK 1-gang back box, landscape or portrait

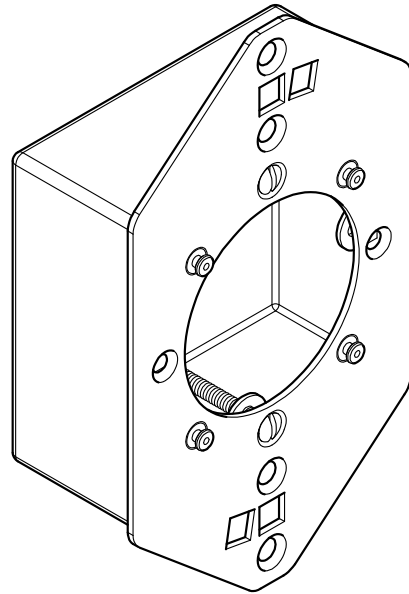
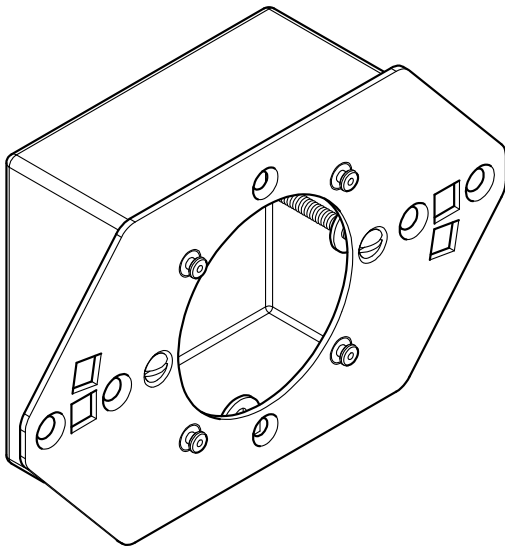

- EU 1-gang back box, landscape or portrait

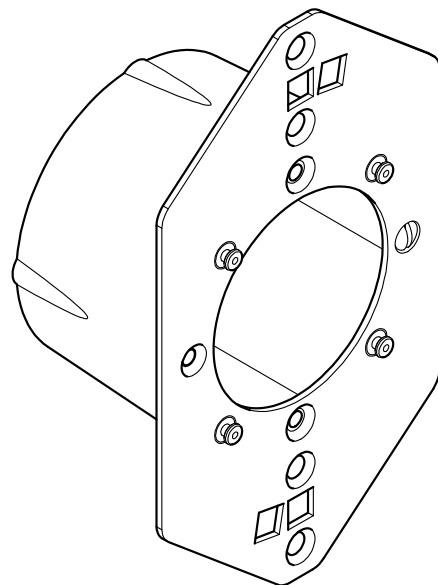
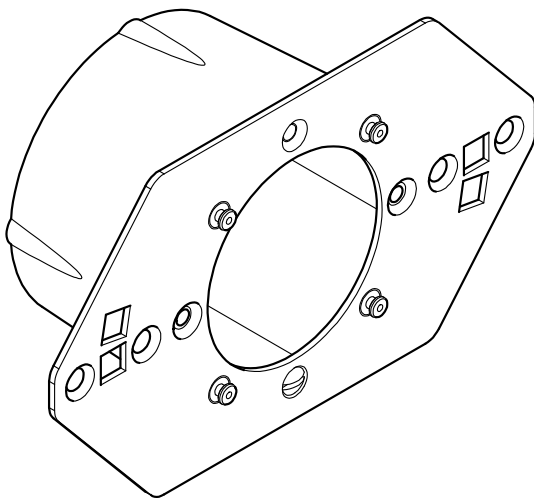

- UK 2-gang back box

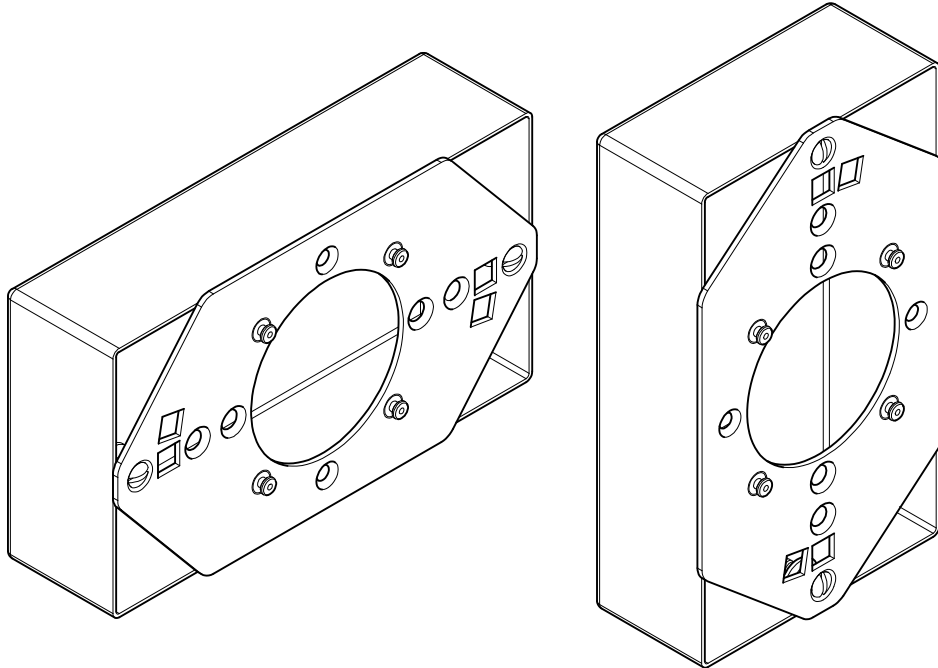

- US 1-gang back box

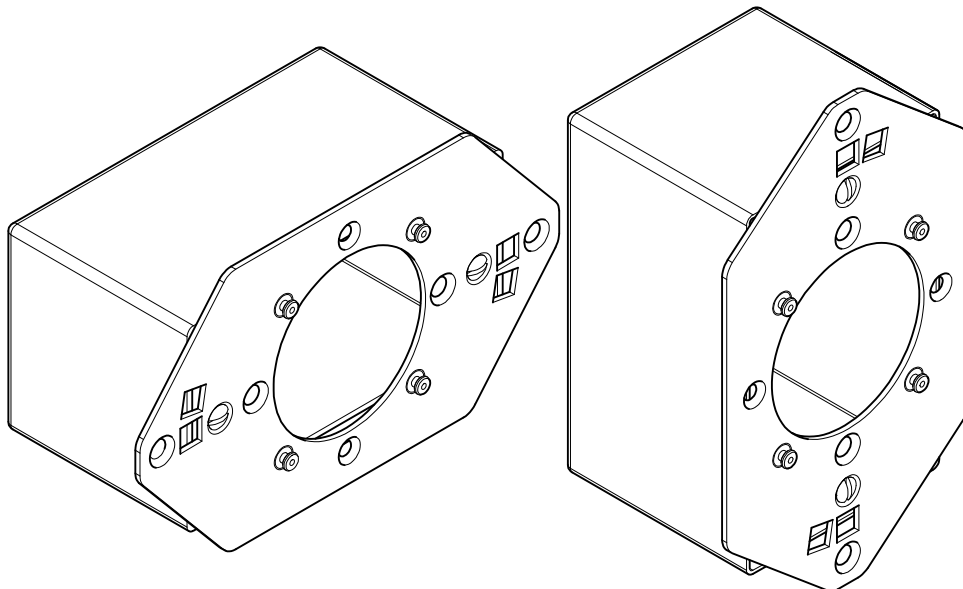

## WIRING DIAGRAM

Illustrative example of possible wiring for an Expert control system, including all Expert accessory devices.

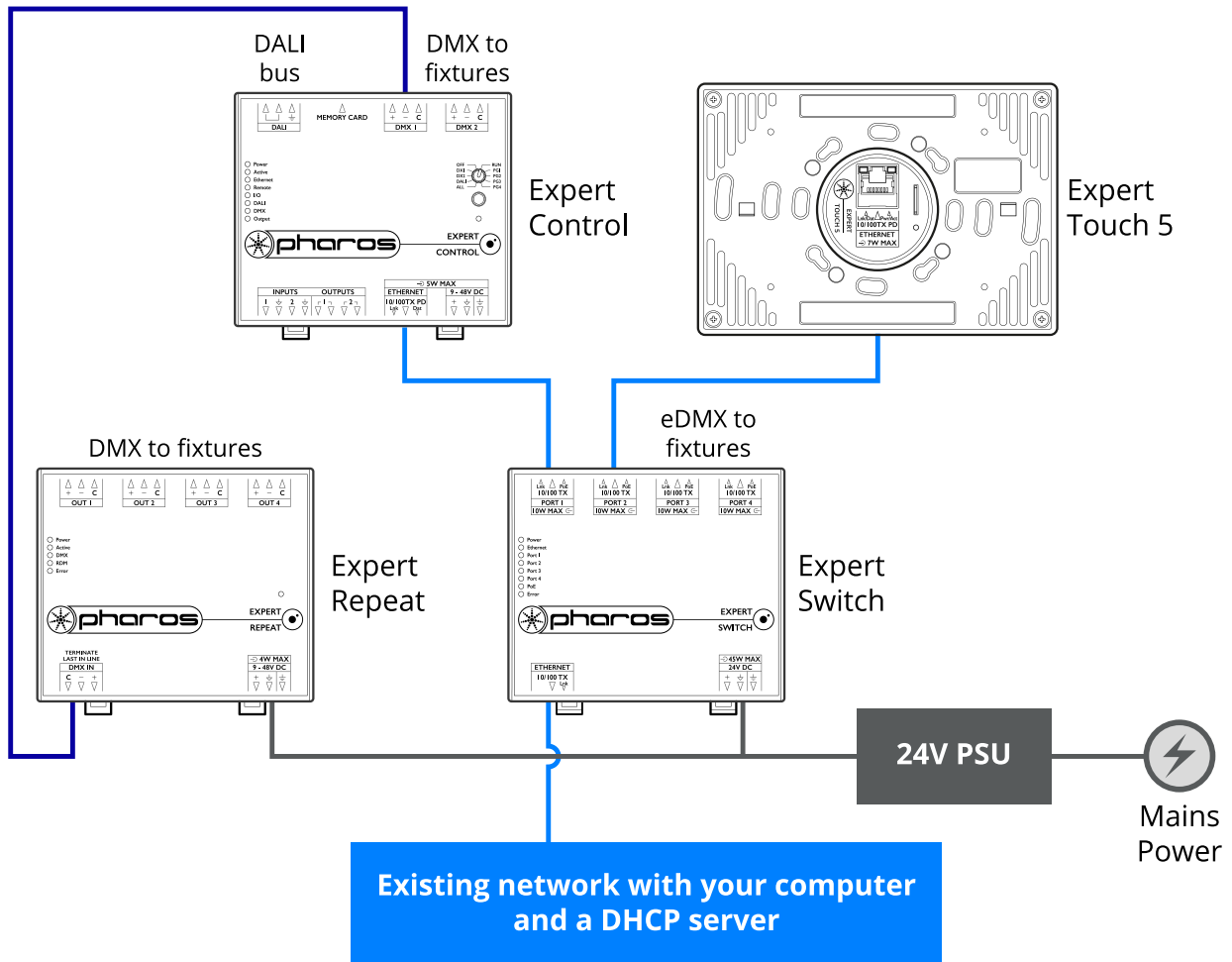

## WARRANTY

This Pharos Architectural Controls Limited ("Pharos") product is warranted for the period of five (5) years from the original date of purchase against defective materials and workmanship.

In the event that warranty service is required, you should contact your dealer or Pharos technical support at the following email address: [support@pharoscontrols.com](mailto:support@pharoscontrols.com).

## CONDITIONS

1. The warranty is only valid if the Pharos software registration is fully and properly completed, Pharos is presented with the original invoice or sales confirmation, Pharos has received payment in full and the serial number on the product has not been defaced.
2. Pharos' obligations are limited to the repair or, at its discretion, replacement of the product or the defective part.
3. It is the consumer's obligation to notify Pharos within one week of any suspected defect, and to return the goods prepaid to Pharos' authorised service address. Goods will only be received under warranty when they are returned with a recognised RMA number that has been issued by Pharos.
4. Warranty repairs must be carried out by a nominated Pharos employee or Pharos approved service technician. No reimbursement will be made for repairs carried out by non-Pharos personnel or dealers, and any such repair work or damage to the product caused by such repair work will not be covered by this warranty.
5. This product is not considered to be defective in materials or workmanship by reason that it requires adaptation in order to conform to national or local technical or safety standards in force in any country other than the one for which the product was originally designed or manufactured. This warranty will not cover, and no reimbursement will be made for such adaptation or any damage which may result.
6. This warranty covers none of the following:
  - a. Maintenance and repair or replacement of parts due to normal wear and tear.
  - b. Cost relating to transport, removal or installation of the product.
  - c. Misuse, including the failure to use this product for its normal purposes or incorrect installation.
  - d. Damage caused by lightning, water, fire, acts of God, war, public disturbances, incorrect supply voltage, improper ventilation or any other cause beyond the control of Pharos.
7. This warranty is valid for any person who legally acquired possession of the product during the warranty period.
8. The consumer's statutory rights in any applicable national legislation arising from the purchase are not affected by this warranty. The rights under this warranty are the consumer's sole rights and Pharos, its subsidiaries or distributors shall not be liable for any indirect or consequential loss, damages for any loss of use, time, profits or income, or any damage to related equipment, materials or consumable parts.