

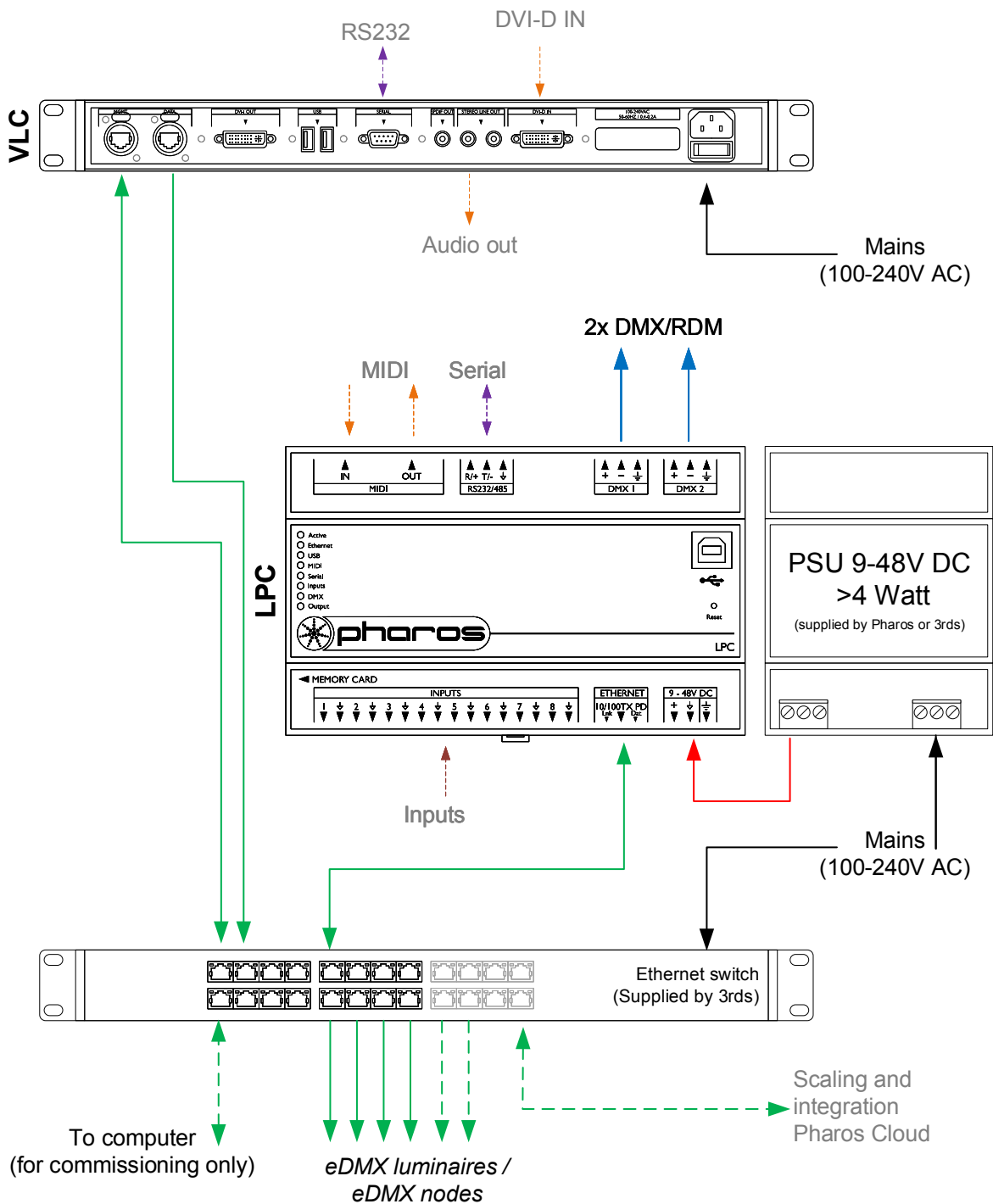

Type:	LPC 1	LPC 2	LPC 4
1:DMX 1	≤ 512 channels	≤ 512 channels	≤ 512 channels
1:DMX 2	Clone to DMX1	≤ 512 channels	≤ 512 channels
eDMX	≤ 512 channels	≤ 1,024 channels	≤ 2,048 channels
Total	≤ 512 channels	≤ 1,024 channels	≤ 2,048 channels
Type:	VLC__(=__=50,100,250,500,1000,1500) (e.g. VLC 100)		
eDMX	≤ __*512 (e.g. 51,200 channels) (DMX via eDMX Nodes)		
Total	≤ __*512 (e.g. 51,200 channels)		

Note: The VLC channels are used to control a single composition of fixtures. The DVI-D input is local to the VLC channels. The LPC can control its channels with complete freedom. The VLC and LPC can be programmed and triggered in the same project.



- Consult the **Installation Guide** for technical details
- See **General Notes.pdf** for information on cabling types
- **More configurations** are possible to fulfil any project
- Contact your supplier or visit our website for support

 pharoscontrols.com	Reference: 2110	Name: LPC & VLC (single network)	
	Size: A4	Date: 17/09/2018	Rev: V 1.0
	Page:	Notes: Setup	
		21/01/2019	V 1.2
		27/05/2021	V 1.3